

MEGAMASTER SERIES FPS 25000

TWO-AXIS POSITIONER, 25000 kg CAPACITY

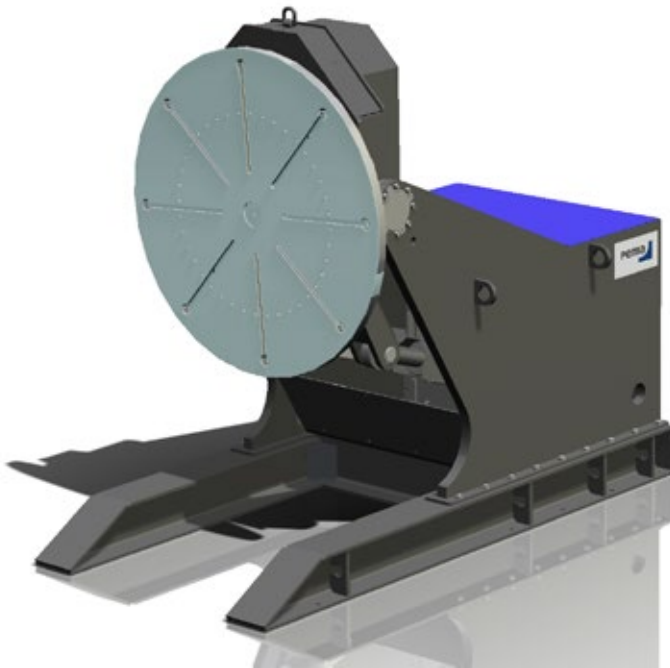

Technical data

Max. load (N)	250 000
Rotation speed (rpm)	0,02-0,4
Max. rotational torque (Nm)	40 000
Tilting torque (Nm)	175 000
Tilting / angle (°)	hydr. 110
Tilting time 0-max angle (s)	170
Table plate diameter (mm)	1950
T-slots on table plate	8x M24 DIN508
Max.welding current (A)	2100
Height (mm)	2500
Width (mm)	1950
Length (mm)	3840
Weight (kg)	11000
Mains supply connection 50 Hz	3x400V+N+PE
Power (A)	35

Due to continuous R&D, Pemamek Ltd reserves the right to change the specification without notice.

PEMA MEGAMASTER SERIES

PEMA FPS 25000 - 250 000 Megamaster positioners are at their best when large and heavy objects are handled. They offer exceptional loading characteristics in both rotation and tilting, and their massive frames ensure safety at all times.

- Work-pieces can be set to the best possible welding positions. As a result welding productivity can be raised significantly.

- Hundreds of man-hours saved yearly compared to manual work-piece handling. With PEMA Megamaster these hours can be used on actual productive work.

- Fast welding in down-hand positions
- Optimum welding parameters
- Quality improvement – less finishing and repairing
- Accuracy, safety and ergonomics
- Integrability with Pema's Column & Booms
- Extensive world-wide PEMA service
- Fast delivery and production start-up

BETTER PRODUCTIVITY

Rotate or tilt the workpiece. Megamaster guarantees optimal working position, always.

IMPROVED QUALITY

Good ergonomics and safety secure welder's high motivation and working quality.

DESIGNED TO LAST

Engineered to endure even the most robust conditions. Partner that will not let you down.



MEGAMASTER SERIES
FPS 25000

TWO-AXIS POSITIONER, 25000 kg CAPACITY

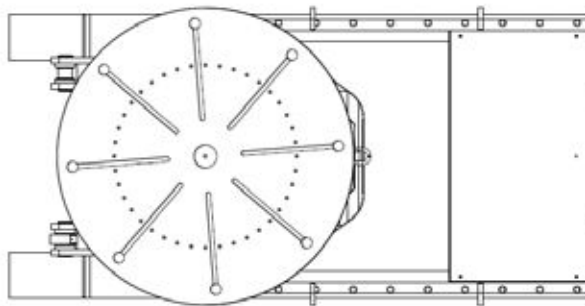
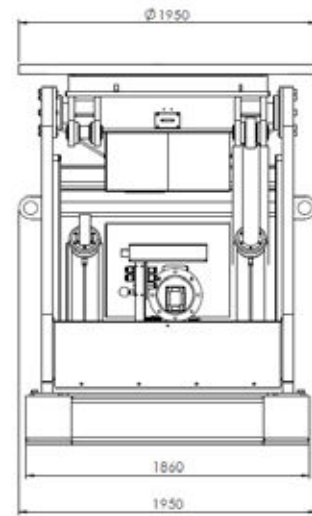
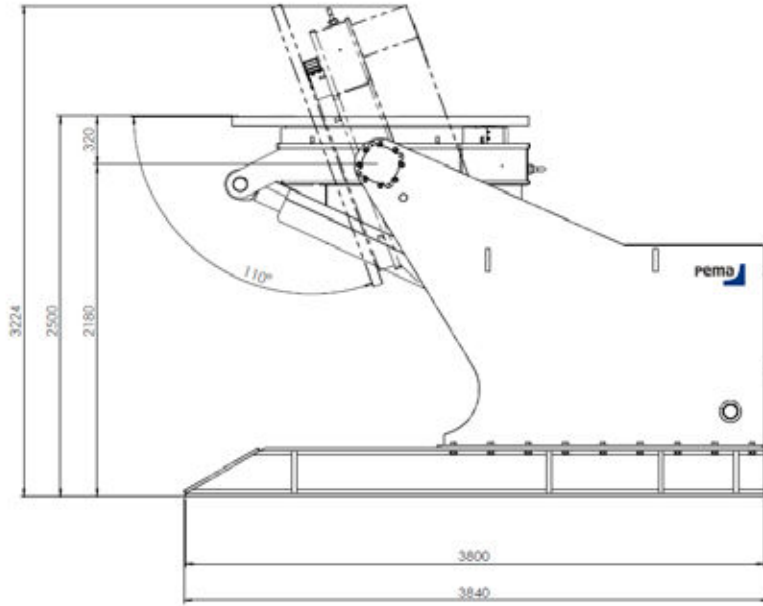

Wired RC32H-remote included.

Optional accessories

- External control of rotation
- Wireless remote control

LOAD CAPACITY DIAGRAMS

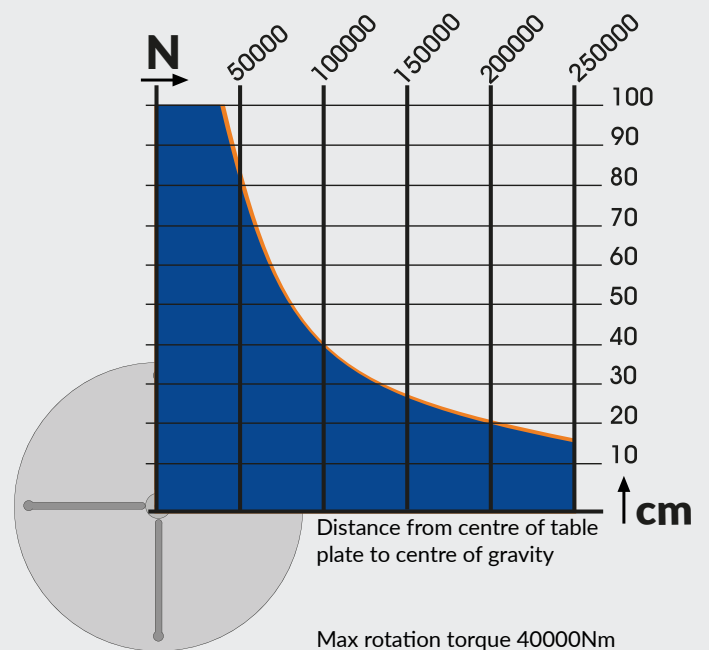
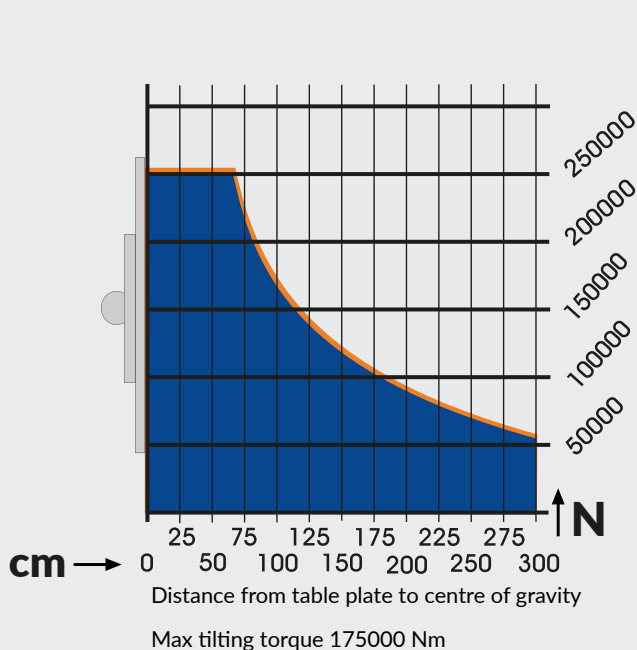

MEGAMASTER SERIES FPS 35000

TWO-AXIS POSITIONER, 35000 kg CAPACITY



Technical data

Max. load (N)	350 000
Rotation speed (rpm)	0,02-0,4
Max. rotational torque (Nm)	55 000
Tilting torque (Nm)	280 000
Tilting / angle (°)	hydr. 110
Tilting time 0-max angle (s)	170
Table plate diameter (mm)	1950
T-slots on table plate	8x M24 DIN508
Max.welding current (A)	2100
Height (mm)	2500
Width (mm)	1950
Length (mm)	3840
Weight (kg)	11000
Mains supply connection 50 Hz	3x400V+N+PE
Power (A)	50

Due to continuous R&D, Pemamek Ltd reserves the right to change the specification without notice.

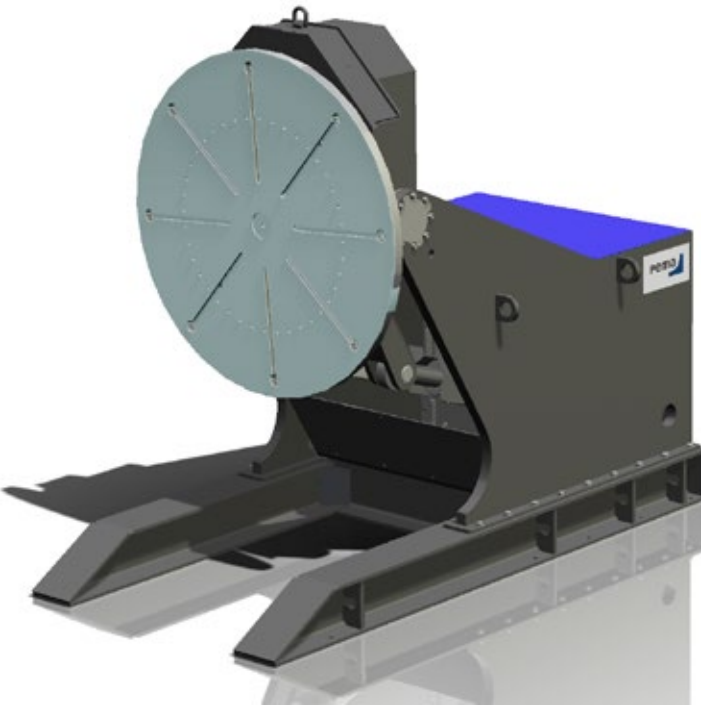

PEMA MEGAMASTER SERIES

PEMA FPS 25000 - 250 000 Megamaster positioners are at their best when large and heavy objects are handled. They offer exceptional loading characteristics in both rotation and tilting, and their massive frames ensure safety at all times.

- Work-pieces can be set to the best possible welding positions. As a result welding productivity can be raised significantly.

- Hundreds of man-hours saved yearly compared to manual work-piece handling. With PEMA Megamaster these hours can be used on actual productive work.

- Fast welding in down-hand positions
- Optimum welding parameters
- Quality improvement – less finishing and repairing
- Accuracy, safety and ergonomics
- Integrability with Pema's Column & Booms
- Extensive world-wide PEMA service
- Fast delivery and production start-up

BETTER PRODUCTIVITY

Rotate or tilt the workpiece. Megamaster guarantees optimal working position, always.

IMPROVED QUALITY

Good ergonomics and safety secure welder's high motivation and working quality.

DESIGNED TO LAST

Engineered to endure even the most robust conditions. Partner that will not let you down.



MEGAMASTER SERIES
FPS 35000

TWO-AXIS POSITIONER, 35000 kg CAPACITY

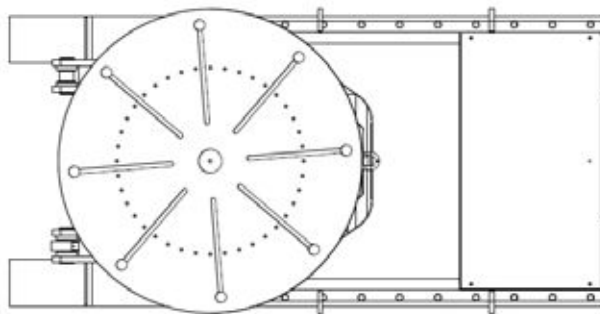
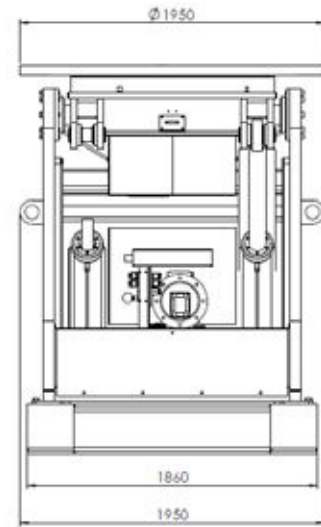
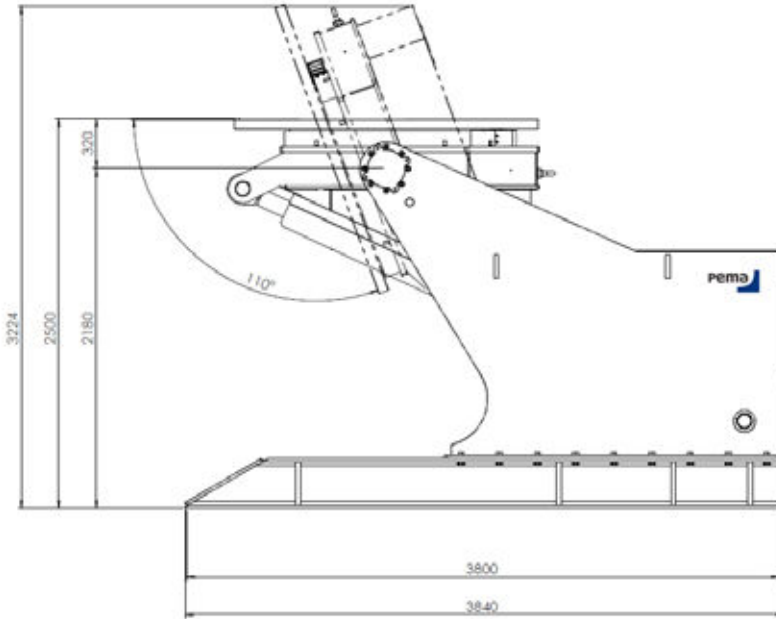

Wired RC32H-remote included.

Optional accessories

- External control of rotation
- Wireless remote control

LOAD CAPACITY DIAGRAMS

